

REV	Eng	Date:	Revision Description	ECN#
A				
B				
C				
D				
E				
F				

INDEX

SHEET	DESCRIPTION

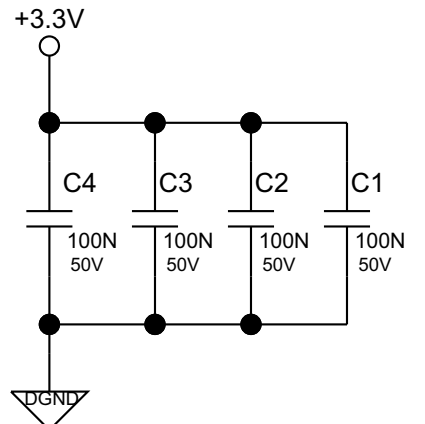

Note: All thru hole Resistors are 1/4 Watt unless otherwise indicated.
 All SMT 1206 Resistors are 1/4 Watt.
 All SMT 0805 Resistors are 1/10 Watt.
 Note Capacitor Values are indicated as Follows:
 val P = pF (picoFarads) val * 10 exp-12
 val N = nF (nanoFarads) val * 10 exp-9 (1N=1000pF, 100N=0.1uF)
 val U = uF (microFarads) val * 10 exp-6

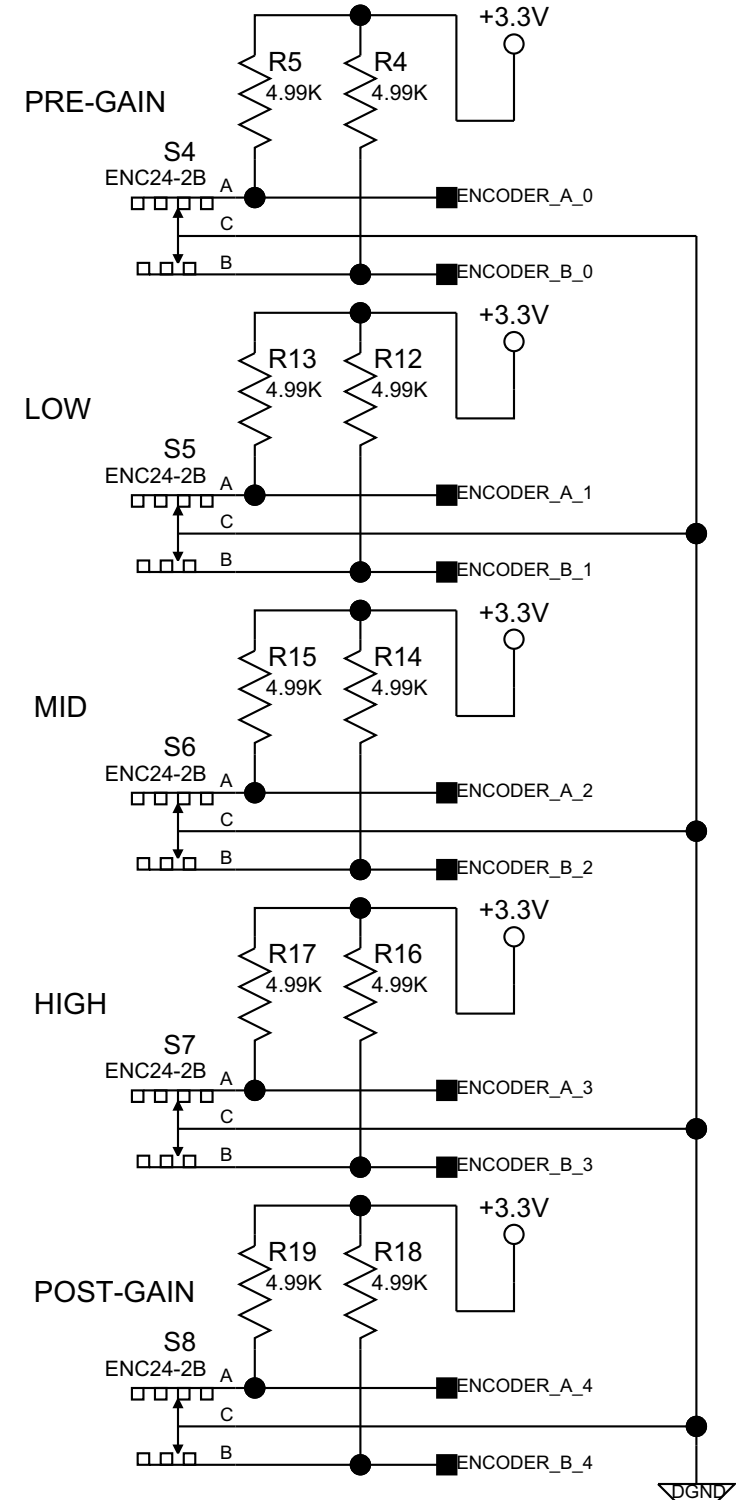
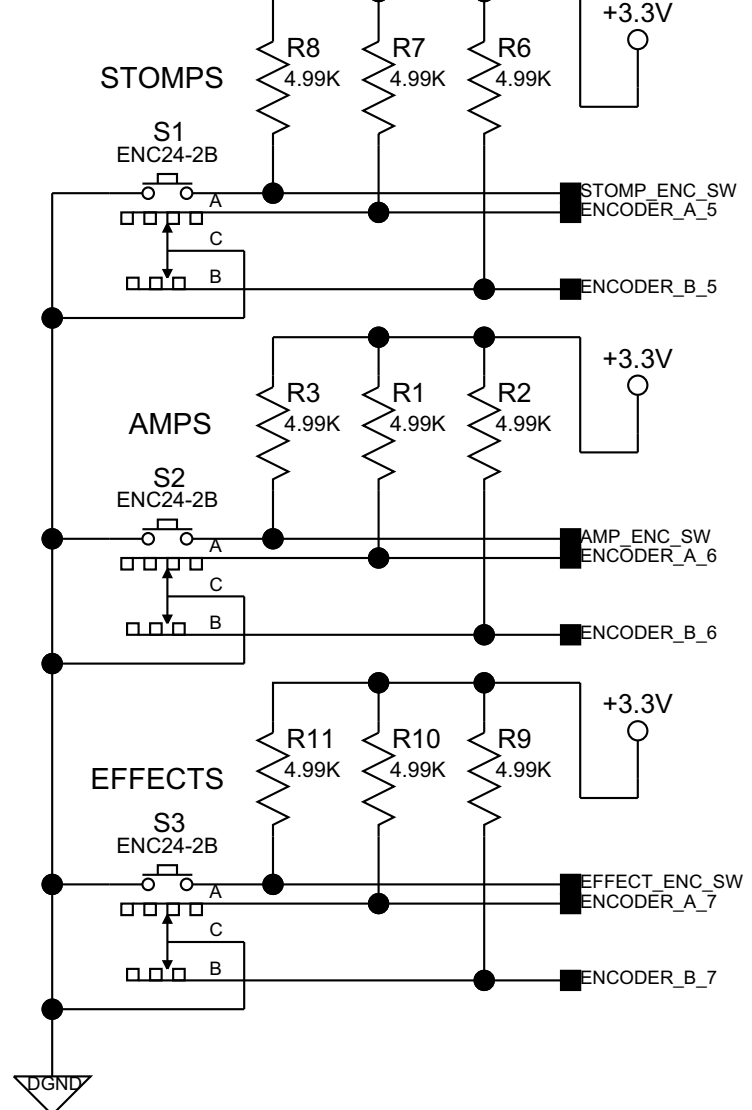
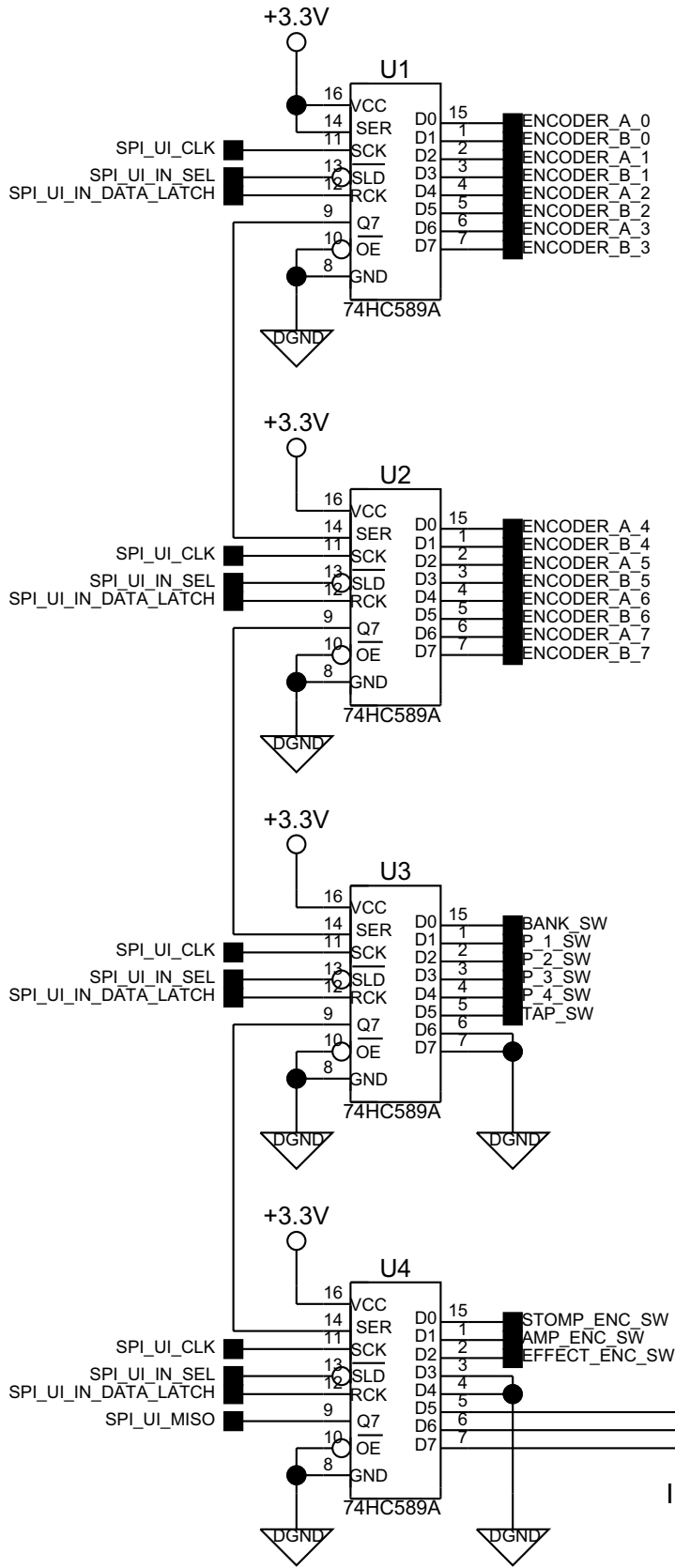

Company Proprietary Information



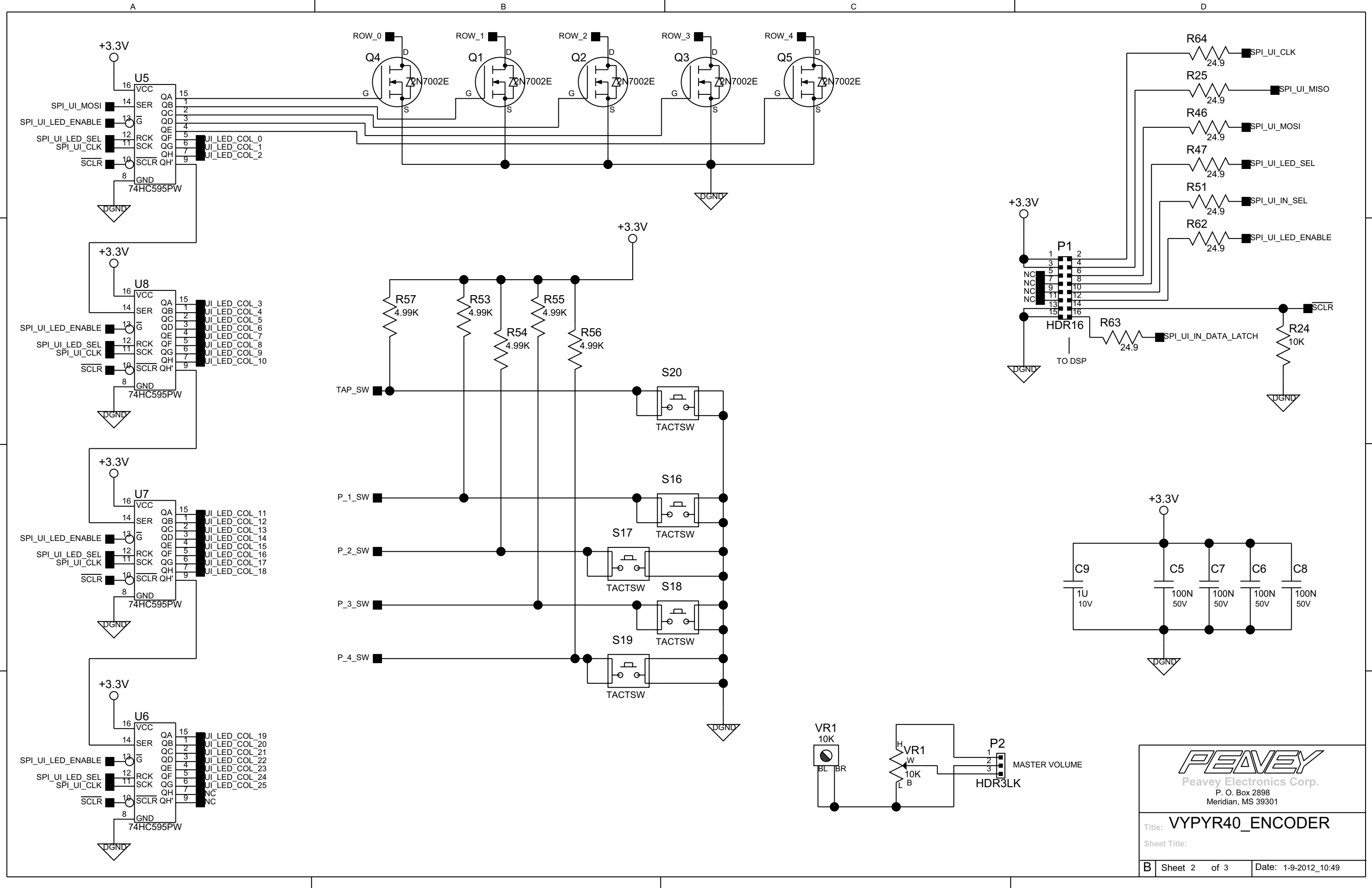

Product:	
Title: VYPYR40_ENCODER	
Project Number:	
Eng:	Release Date:
B Sheet 1 of 3	Saved: 1-9-2012_10:49

Patents:
 Copyright Peavey Electronics Corporation 2008.

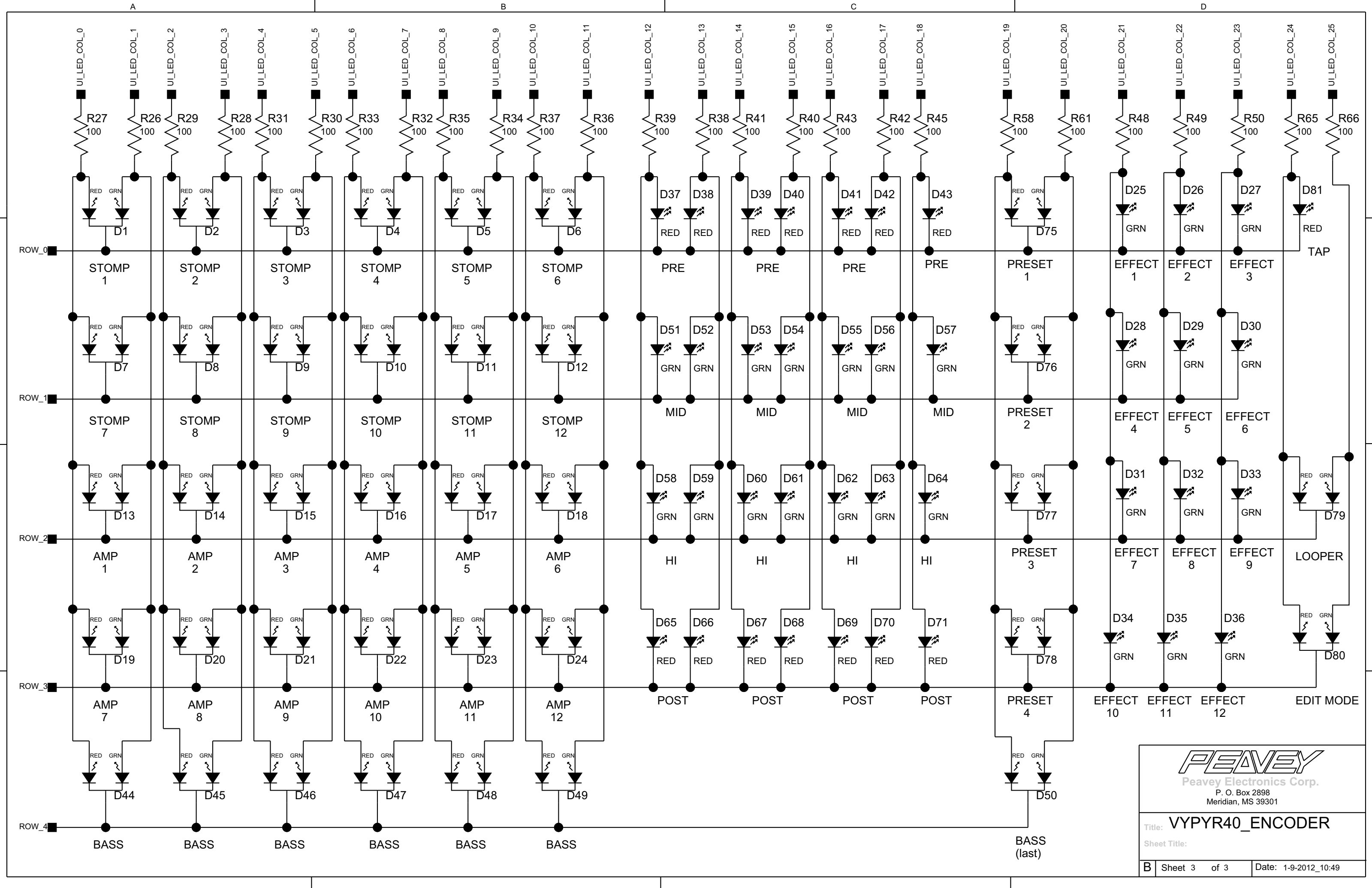

Title: VYPYR40_ENCODER
Sheet Title:



 Peavey Electronics Corp.
 P. O. Box 2898
 Meridian, MS 39301

Title: **VYPYR40_ENCODER**
 Sheet Title:

B Sheet 3 of 3 Date: 1-9-2012_10:49

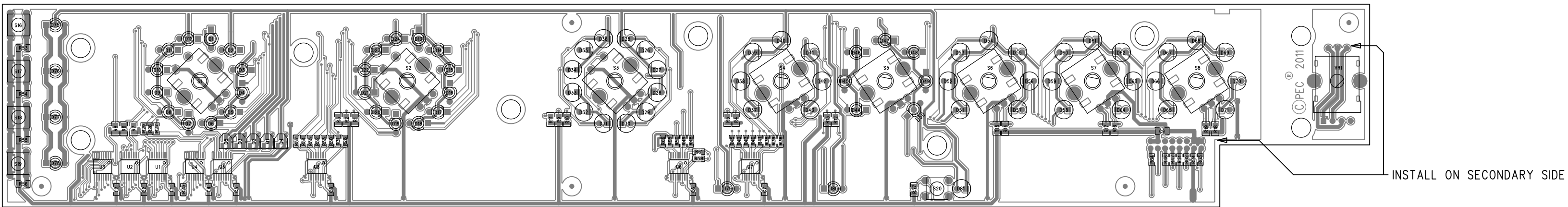

INSTALL ON SECONDARY SIDE

BILL OF MATERIAL REPORT

REPORT DATE/TIME: 1/12/2012 3:17:10 PM

BOARD NAME: Vypyr VIP II Encoder 40TT ASSEMBLY LEVEL NUMBER:
32203000

PROJECT NUMBER: P1100025 DESIGNER: FJE - 32101804C

Qty.	Part #	Description	Reference

Designators			
24	30200173	4.99K 1/10W 1% MF 0805	R1 R2 R3 R4 R5 R6 R7 R8 R9 R10 R11 R12 R13 R14 R15 R16 R17 R18 R19 R53 R54 R55 R56 R57
26	30200287	100 1/10W 1% MF 0603	R26 R27 R28 R29 R30 R31 R32 R33 R34 R35 R36 R37 R38 R39 R40 R41 R42 R43 R45 R48 R49 R50 R58 R61 R65 R66
1	30200289	10K 1/10W 1% MF 0603	R24
7	30200298	24.9 1/10W 1% MF 0603	R25 R46 R47 R51 R62 R63 R64
1	30300094	1UF 10V 10% X7R 0805	C9
8	30300128	0.1UF 50V □20% Y5V 0603	C1 C2 C3 C4 C5 C6 C7 C8
5	30418369	2N7002E N CH 60V MOSFET	Q1 Q2 Q3 Q4 Q5
4	30418588	74HC595PW 8-TRI SHIFT REG SMT	U5 U6 U7 U8
4	30418732	74HC589 8-BIT SHIFT REGISTER	U1 U2 U3 U4
15	30450053	RED T1 LED W/STOP LEAD	D37 D38 D39 D40

			D41 D42 D43 D65 D66 D67 D68 D69 D70 D71 D81
26	30450054	GRN T1 LED W/STOP LEAD	D25 D26 D27 D28 D29 D30 D31 D32 D33 D34 D35 D36 D51 D52 D53 D54 D55 D56 D57 D58 D59 D60 D61 D62 D63 D64
37	30450601	BICOLOR LED R/G T1 W/STP BULK	D1 D2 D3 D4 D5 D6 D7 D8 D9 D10 D11 D12 D13 D14 D15 D16 D17 D18 D19 D20 D21 D22 D23 D24 D44 D45 D46 D47 D48 D49 D50 D75 D76 D77 D78 D79 D80
1	31191524	10KB SNGL 12MM VER	VR1
3	31322505	ENCDR 24P 24D 2BIT SW PC V	S1 S2 S3
5	31322506	ENCDR 24P 0D 2BIT PC V	S4 S5 S6 S7 S8
5	31322542	VERTICAL TACT SWITCH 6X6MM	S16 S17 S18 S19 S20
1	33717013	3 HDR V SR .100" TIN LK	P2
1	33717362	16 HDR V DR 2MM GOLD	P1

 END OF BILL OF MATERIAL REPORT
